

Classical Wave Mechanics

Robert Close, PhD.

robert.close@classicalmatter.org

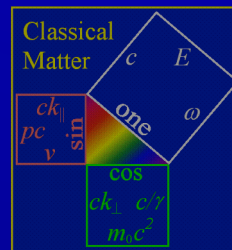

Licensed under a [Creative Commons Attribution-ShareAlike 4.0 International Public License](https://creativecommons.org/licenses/by-sa/4.0/). © Copyright 2020 Robert Close

Motion Fields

Fundamentally, motion has two types:

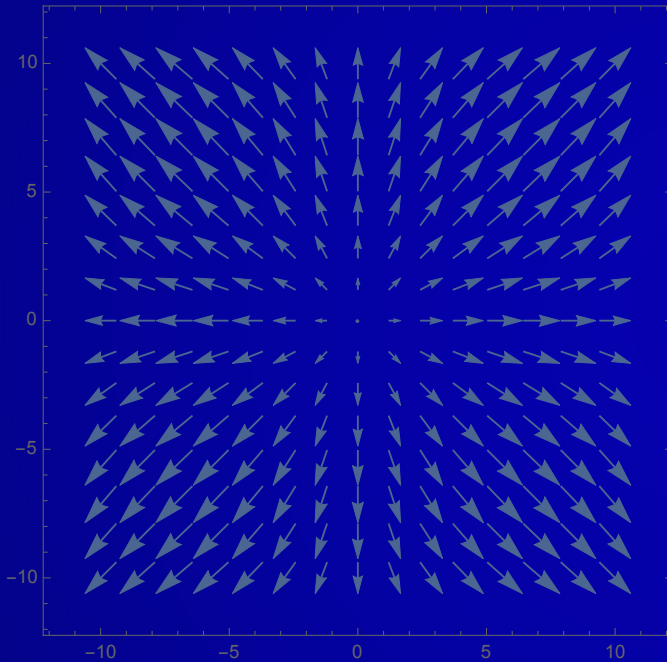

Irrotational

$$\nabla \times \mathbf{u} = 0$$

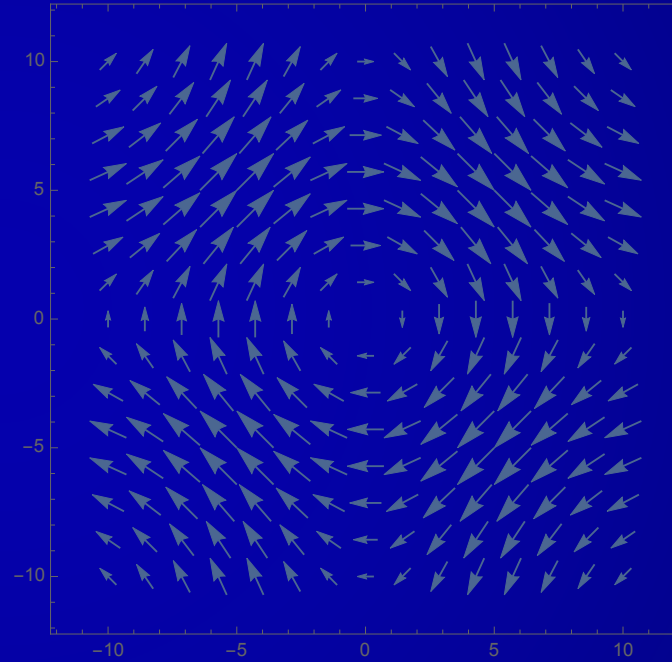

Incompressible
(Rotational)

$$\nabla \cdot \mathbf{u} = 0$$

Incompressible (Rotational) Motion

Helmholtz Decomposition applied to
momentum density:

$$\mathbf{p} \equiv \rho \mathbf{u} = \frac{1}{2} \nabla \times \mathbf{s} + \nabla \Phi + \mathbf{p}_0$$

Incompressible, co-moving: $\nabla \Phi = 0$, $\mathbf{p}_0 = 0$

$$\nabla \cdot \mathbf{u} = 0 \rightarrow \rho = \text{constant}$$

$$\nabla \cdot \rho \mathbf{u} = 0$$

Spin Angular Momentum

$$\nabla \cdot \mathbf{p} = 0 \quad \mathbf{p} = \frac{1}{2} \nabla \times \mathbf{s}$$

Spin angular momentum density is the unique vector potential in the Helmholtz decomposition of momentum density.

Its curl is equal to twice the incompressible momentum density ($\mathbf{p} = \rho \mathbf{u}$).*

*R. A. Close, "A classical Dirac bispinor equation," in *Ether Space-time & Cosmology, vol. 3*, edited by M. C. Duffy and J. Levy (Apeiron, Montreal, 2009).

See also Publications at the end of this slide show.

Angular Momentum Density

$$\mathbf{p} = \rho \mathbf{v} = \frac{1}{2} \nabla \times \mathbf{s}; \quad \mathbf{w} = \frac{1}{2} \nabla \times \mathbf{v}$$

$$\mathbf{J} = \int \mathbf{r} \times \mathbf{p} \, d^3 r = \int \mathbf{s} \, d^3 r + \text{b. t.}$$

$$K = \int \frac{1}{2} \rho v^2 \, d^3 r = \int \frac{1}{2} \mathbf{w} \cdot \mathbf{s} \, d^3 r + \text{b. t.}$$

Spin density yields the same total angular momentum and kinetic energy as conventional angular momentum density.

Conjugate Momentum

$$\frac{\delta}{\delta \mathbf{w}} \int \frac{1}{2} \rho v^2 d^3 r = \frac{\delta}{\delta \mathbf{w}} \int \frac{1}{2} \mathbf{w} \cdot \mathbf{s} d^3 r = \mathbf{s}$$

If the Lagrange density is $\mathcal{L} = \frac{1}{2} \rho v^2$ then the momentum conjugate to angular velocity \mathbf{w} is the spin density \mathbf{s} .

Rotating Cylinder

Parabolic radial distribution of spin density.

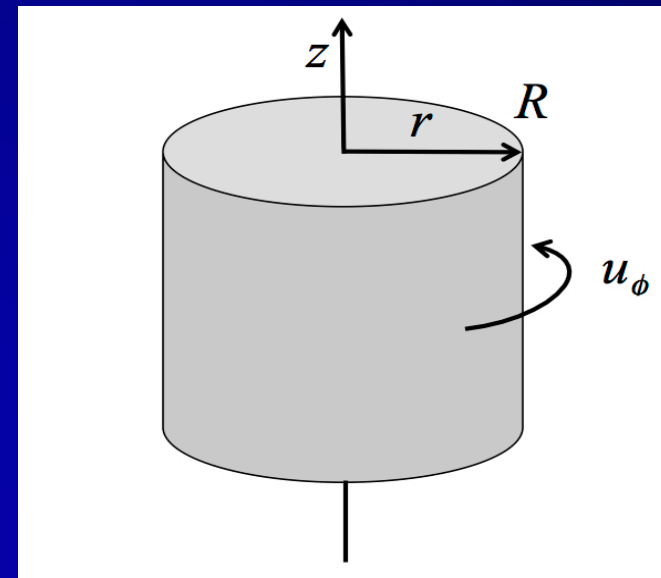

$$\mathbf{s} = \rho w_0 [R^2 - r^2]$$

$$r \leq R$$

$$u_\phi = \frac{1}{2\rho} \frac{\partial}{\partial r} s_z = r w_0$$

$$r \leq R$$

$$w_z = \frac{1}{2r} \frac{\partial}{\partial r} r u_\phi$$

$$= w_0 [1 - R\delta(R - r)/2] \quad r \leq R$$

Rotating Cylinder

Integration yields the usual total angular momentum and kinetic energy.

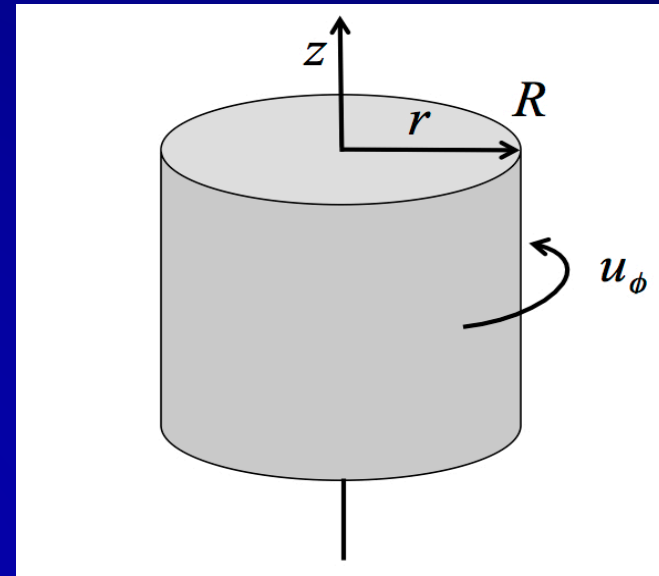

$$J_z = \int s_z d^3r = \frac{MR^2}{2} \omega_0 = I\omega_0$$

$$K = \int \frac{1}{2} \rho u^2 d^3r = \int \frac{1}{2} \mathbf{w} \cdot \mathbf{s} d^3r$$

$$= \frac{1}{2} \frac{MR^2}{2} \omega_0^2 = \frac{1}{2} I\omega_0^2$$

Part I Summary

1. There is a classical analogue of spin angular momentum density:

$$\mathbf{p} = \rho \mathbf{u} = \frac{1}{2} \nabla \times \mathbf{s}$$

2. Quantum mechanical spin angular momentum is the angular momentum of the medium in which matter waves travel (vacuum or aether).

Classical Wave Mechanics

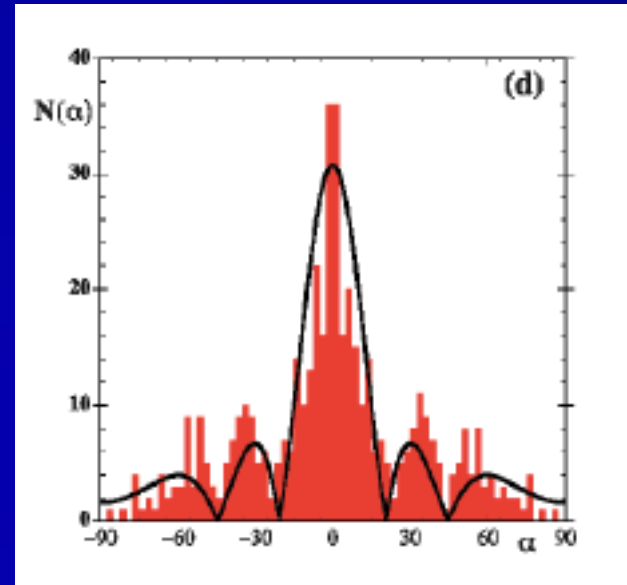
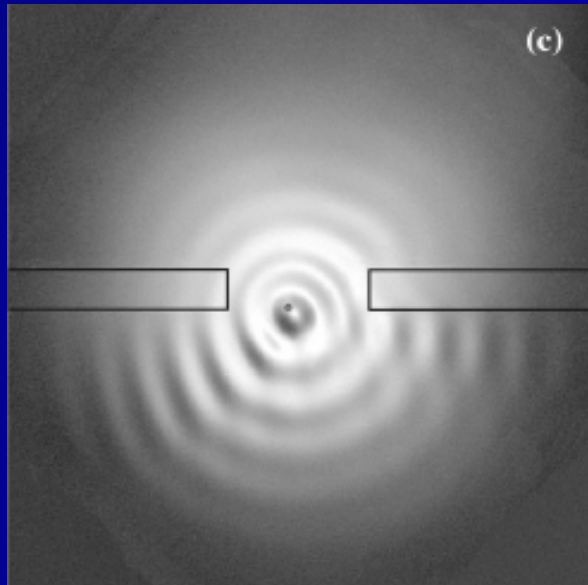

Couder & Fort , PRL **97**, 154101 (2006)

“Classical” physics can reproduce many quantum phenomena.

(see <https://www.youtube.com/watch?v=RkJ2eqAqazI>)

Equation of Evolution

A possible equation of evolution for spin density equation the total time derivative with torque density:

$$D_t \mathbf{s} = (\partial_t + \mathbf{u} \cdot \nabla - \mathbf{w} \times) \mathbf{s} = \boldsymbol{\tau}$$

We will assume that nonlinear terms cancel (or are otherwise negligible) so that:

$$\partial_t \mathbf{s} \equiv \partial_t^2 \mathbf{Q} = c^2 \nabla^2 \mathbf{Q}$$

Wave Equation

- 1-D Wave Equation

$$\partial_t^2 a + c^2 \partial_z^2 a = 0$$

- Solution is Forward + Backward waves:

$$a(z, t) = a_F(z - ct) + a_B(z + ct)$$

- In 3-D these independent solutions are 180° apart. Hence the wave solutions form a spin one-half system (3-D requires bispinors).



Wave Equation

- To accommodate rotation, separate positive and negative time derivative components:

$$\begin{aligned}\partial_t a(z, t) = & \dot{a}_{F+}(z - ct) \\ & - \dot{a}_{F-}(z - ct) \\ & + \dot{a}_{B+}(z + ct) \\ & - \dot{a}_{B-}(z + ct)\end{aligned}$$

Define the wave function (chiral representation):

$$\psi(z, t) = \begin{bmatrix} (\dot{a}_{B+})^{1/2} \\ (\dot{a}_{F-})^{1/2} \\ (\dot{a}_{F+})^{1/2} \\ (\dot{a}_{B-})^{1/2} \end{bmatrix}$$

Wave Equation

- The 1-D wave equation is:

$$0 = \partial_t(\psi^T \sigma_z \psi) + \partial_z(\psi^T \gamma^5 c \psi)$$

where:

$$\psi^T \sigma_z \psi = \begin{bmatrix} (\dot{a}_{B+})^{1/2} \\ (\dot{a}_{F-})^{1/2} \\ (\dot{a}_{F+})^{1/2} \\ (\dot{a}_{B-})^{1/2} \end{bmatrix}^T \begin{pmatrix} 1 & 0 & 0 & 0 \\ 0 & -1 & 0 & 0 \\ 0 & 0 & 1 & 0 \\ 0 & 0 & 0 & -1 \end{pmatrix} \begin{bmatrix} (\dot{a}_{B+})^{1/2} \\ (\dot{a}_{F-})^{1/2} \\ (\dot{a}_{F+})^{1/2} \\ (\dot{a}_{B-})^{1/2} \end{bmatrix} = \partial_t a$$

$$\psi^T c \gamma^5 \psi = \begin{bmatrix} (\dot{a}_{B+})^{1/2} \\ (\dot{a}_{F-})^{1/2} \\ (\dot{a}_{F+})^{1/2} \\ (\dot{a}_{B-})^{1/2} \end{bmatrix}^T \begin{pmatrix} -1 & 0 & 0 & 0 \\ 0 & -1 & 0 & 0 \\ 0 & 0 & 1 & 0 \\ 0 & 0 & 0 & 1 \end{pmatrix} \begin{bmatrix} (\dot{a}_{B+})^{1/2} \\ (\dot{a}_{F-})^{1/2} \\ (\dot{a}_{F+})^{1/2} \\ (\dot{a}_{B-})^{1/2} \end{bmatrix} = -\partial_z a$$

Dirac Equation

These definitions yield (for $a = Q_z/2$):

$$s_z = \partial_t Q_z = \psi^\dagger \sigma_z \psi / 2$$

$$c \partial_z Q_z = -\psi^\dagger \gamma^5 \psi / 2$$

1-D wave equation:

$$0 = \psi^T \sigma_z \{ \partial_t \psi + \psi^T c \gamma^5 \sigma_z \partial_z \psi \} + \text{Transpose}$$

3-D wave equation:

$$0 = \partial_t [\psi^\dagger \boldsymbol{\sigma} \psi] + c \nabla [\psi^\dagger \gamma^5 \psi] \\ - ic [\nabla \psi^\dagger \times \boldsymbol{\sigma} \psi + \psi^\dagger \gamma^5 \boldsymbol{\sigma} \times \nabla \psi]$$

Dirac Equation

Where:

$$\mathbf{s} = \partial_t \mathbf{Q} = \frac{1}{2} \psi^\dagger \boldsymbol{\sigma} \psi$$

$$c \nabla \cdot \mathbf{Q} = -\frac{1}{2} \psi^\dagger \gamma^5 \psi$$

$$c^2 \nabla \times \nabla \times \mathbf{Q} = \frac{-i c}{2} [\nabla \psi^\dagger \times \boldsymbol{\sigma} \psi + \psi^\dagger \gamma^5 \boldsymbol{\sigma} \times \nabla \psi]$$

$$0 = \frac{-i c}{2} \nabla \cdot [\nabla \psi^\dagger \times \boldsymbol{\sigma} \psi + \psi^\dagger \gamma^5 \boldsymbol{\sigma} \times \nabla \psi]$$

Dirac Equation

Dirac equation for an ideal elastic solid:

$$0 = \partial_t [\psi^\dagger \boldsymbol{\sigma} \psi] + c \nabla [\psi^\dagger \gamma^5 \psi] \\ - ic [\nabla \psi^\dagger \times \boldsymbol{\sigma} \psi + \psi^\dagger \gamma^5 \boldsymbol{\sigma} \times \nabla \psi]$$

The Dirac equation for a free fermion is exactly the same. The equation for the electron wave function is:

$$0 = \partial_t \psi + c \gamma^5 \boldsymbol{\sigma} \cdot \nabla \psi + iM \gamma^0 \psi$$

Gamma Matrices

Gamma matrices define directions relative to velocity:

$$\gamma^0 = \begin{pmatrix} 0 & 0 & 1 & 0 \\ 0 & 0 & 0 & 1 \\ 1 & 0 & 0 & 0 \\ 0 & 1 & 0 & 0 \end{pmatrix} \quad \gamma^4 = - \begin{pmatrix} 0 & 0 & -i & 0 \\ 0 & 0 & 0 & -i \\ i & 0 & 0 & 0 \\ 0 & i & 0 & 0 \end{pmatrix}$$

$$\gamma^5 = - \begin{pmatrix} 1 & 0 & 0 & 0 \\ 0 & 1 & 0 & 0 \\ 0 & 0 & -1 & 0 \\ 0 & 0 & 0 & -1 \end{pmatrix}$$

Compare with $(\sigma_x, -\sigma_y, -\sigma_z)$. Spatial reflection inverts ALL gamma matrices, and exchanges matter and antimatter.*
The quantum "parity" operator incorrectly preserves γ^0 .

***Adv. App. Clifford Algebras 21:283-295, 2010**

Matter and Antimatter

- "Parity violation" experiments instead demonstrate that matter and antimatter are mirror images. The mirror image of a left-handed neutrino is a right-handed antineutrino, etc.

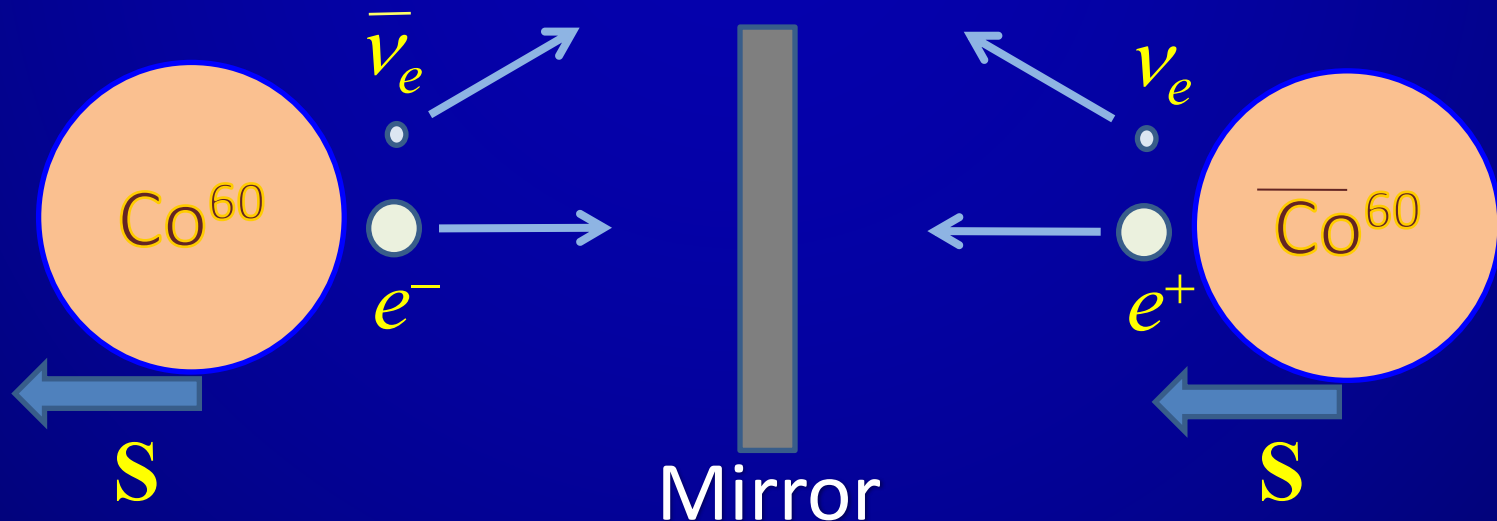

Plane Waves

Longitudinal Wave:

$$\psi = \sqrt{2\omega Q_0} \exp [i (\omega t - kz)/2] \begin{bmatrix} 0 \\ \sin (\omega t - kz)/2 \\ \cos (\omega t - kz)/2 \\ 0 \end{bmatrix}$$

Is equivalent to:

$$Q = (0, 0, Q_0 \sin(\omega t - kz))$$

Rotate wave velocity by multiplying:

$\exp [-i\gamma^0 \pi/4]$ and replacing $z \rightarrow x$ or

$\exp [i\gamma^4 \pi/4]$ and replacing $z \rightarrow y$

Plane Waves

Transverse Wave (using $\exp[-i\gamma^0 \pi/4]$):

$$\psi = \sqrt{\omega Q_0} \exp[i(\omega t - kx)/2] \begin{bmatrix} -i \cos(\omega t - kx)/2 \\ \sin(\omega t - kx)/2 \\ \cos(\omega t - kx)/2 \\ -i \sin(\omega t - kx)/2 \end{bmatrix}$$

Is equivalent to:

$$\mathbf{Q} = (0, 0, Q_0 \sin(\omega t - kx))$$

Mass in Dirac equation is a rotation of wave velocity:

$$\partial_t \psi + c\gamma^5 \boldsymbol{\sigma} \cdot \nabla \psi + i\gamma^0 M \psi = 0$$

Wave Model of Special Relativity

Circulating Wave Model of Special Relativity

For a complete explanation, see the book:

The Wave Basis of Special Relativity, by Robert A. Close
(Verum Versa, Portland, Oregon, 2014)

Roll sheet around the long axis to see the wave packets. Touch the ends of the red line on the left.

Left: Stationary standing wave packet propagating along circular paths ($\gamma=1$)

Right: Moving wave packet propagating along helical paths ($\gamma=2$)

Black lines represent wave crests traveling at the speed of light. Both wave packets have the same length of wave crests and the same spacing between crests along the circular direction. The red line represents the distance light travels in one unit of time, as measured by a stationary observer. The internal clock ticks once each time the wave traverses the circle. The moving wave exhibits time dilation (red line only goes half way around), relativistic frequency increase (shorter wavelength), and length contraction (shorter wave packet).

© Copyright 2014 Robert A. Close

Contact Publishing@VerumVersa.com for reprints.

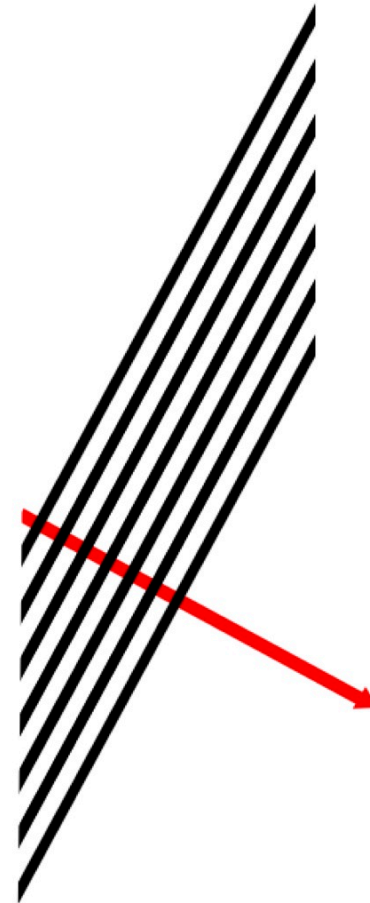
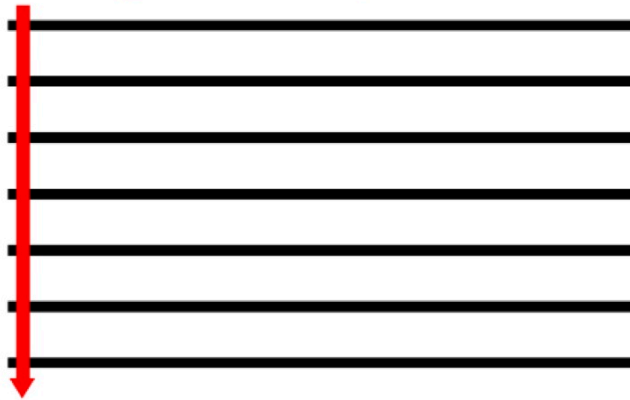

Wave Model of Special Relativity

A moving object has:

1. Higher frequency & energy (kinetic energy).
2. Shorter time (time dilation).
3. Shorter length (length contraction).
4. DeBroglie wavelength.

Video demonstration at Youtube ClassicalMatter:

<https://www.youtube.com/watch?v=GNpixtnmnmfM>

Special Relativity

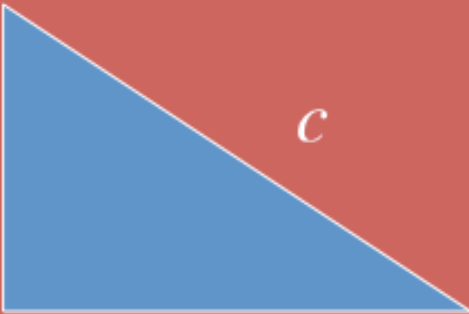
$$\gamma = \frac{c}{\sqrt{c^2 - v^2}}$$
$$\sqrt{c^2 - v^2} = c \left(\frac{\sqrt{c^2 - v^2}}{c} \right) = \frac{c}{\gamma}$$

Multiply by $\gamma m_0 c$:

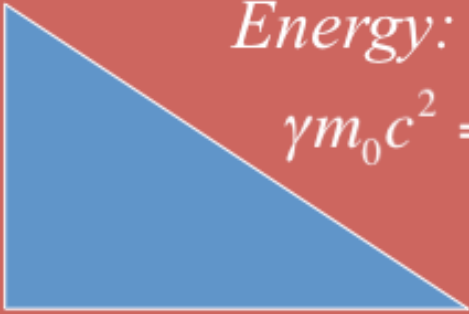

Momentum:
 $(\gamma m_0 v) c = pc$

Energy:
 $\gamma m_0 c^2 = E$

Rest Mass: $m_0 c^2$

Part II Summary

1. The Dirac equation is a 1st order representation of the ordinary 2nd order vector wave equation.
2. The conventional “parity” operator is incorrect. Matter and antimatter are mirror images.
3. Special relativity is a natural consequence of matter consisting of waves in Galilean space-time.

Dirac Equation

The general linear Dirac equation is:

$$\partial_t \psi + c \gamma^5 \boldsymbol{\sigma} \cdot \nabla \psi + i \chi \psi = 0$$

Where χ satisfies: $\text{Re}(\psi^\dagger i \boldsymbol{\sigma} \chi \psi) = 0$

e.g. electron: $\chi = \omega_e \gamma^0 = (m_e c^2 / \hbar) \gamma^0$

The elastic solid Lagrangian and Hamiltonian are the real parts of:

$$\mathcal{L} = i \psi^\dagger \partial_t \psi + c \psi^\dagger \gamma^5 \boldsymbol{\sigma} \cdot i \nabla \psi - \psi^\dagger \chi \psi$$

$$\mathcal{H} = -c \psi^\dagger \gamma^5 \boldsymbol{\sigma} \cdot i \nabla \psi + \psi^\dagger \chi \psi$$

Dirac Equation

Dynamical quantities are equivalent to those of relativistic quantum mechanics:

$$\mathbf{P} = -[\psi^\dagger i\nabla\psi] + \frac{1}{2}\nabla \times \left[\psi^\dagger \frac{\boldsymbol{\sigma}}{2}\psi \right]$$

$$\mathbf{J} = -\mathbf{r} \times [\psi^\dagger i\nabla\psi] + \left[\psi^\dagger \frac{\boldsymbol{\sigma}}{2}\psi \right]$$

The momentum of the medium is necessary for a symmetric energy-momentum tensor compatible with General Relativity. [Ohanian 1986]

Exclusion Principle & Potentials

- Wave superposition:

$$[\psi_A + \psi_B]^\dagger \sigma [\psi_A + \psi_B] = \psi_A^\dagger \sigma \psi_A + \psi_B^\dagger \sigma \psi_B + \psi_A^\dagger \sigma \psi_B + \psi_B^\dagger \sigma \psi_A$$

- Interference terms cancel for “independent” particles. For eigenfunctions this yields the Pauli exclusion principle (anti-commutation):

$$\psi_A^\dagger \psi_B + \psi_B^\dagger \psi_A = 0$$

- Interaction potentials are phase shifts introduced to maintain zero interference.

Exclusion Principle & Potentials

Start with electron wave function ψ_A normalized to 1. Phase-shifted wave satisfies free-particle equation:

$$[\partial_t + c\gamma^5 \boldsymbol{\sigma} \cdot \nabla + i\omega_e \gamma^0] (\exp[-i\delta_A] \psi_A) = 0$$

Force density equals the total time derivative of wave momentum density ($\mathbf{P} = -i\nabla$). No force on phase-shifted wave:

$$\text{Re} \left\{ \psi_A^\dagger e^{i\delta_A} [\partial_t + c\gamma^5 \boldsymbol{\sigma} \cdot \nabla] (-i\nabla) (e^{-i\delta_A} \psi_A) \right\} = 0$$

Exclusion Principle & Potentials

Define: Wave density: $\rho_w = \psi_A^\dagger \psi_A$

Wave current density: $\Gamma = \psi_A^\dagger c\gamma^5 \boldsymbol{\sigma} \psi_A$

Vector potential: $q\mathbf{A} = -\hbar \nabla \delta_A / 2$

Assume: $\rho_w \partial_t \mathbf{A} \gg \mathbf{A} \partial_t \rho_w$. Force density is:

$$d_t \mathbf{P} = \psi_A^\dagger q [-\partial_t \mathbf{A} + c\gamma^5 \boldsymbol{\sigma} \times (\nabla \times \mathbf{A})] \psi_A$$

Weyl gauge:

$\mathbf{B} = \nabla \times \mathbf{A}$ (not zero for multivalued δ_A)

$\mathbf{E} = -\partial_t \mathbf{A}$ (Helmholtz decomp: $-\nabla\Phi - \partial_t \mathbf{A}'$)

Lorentz force:

$$d_t P = \psi_A^\dagger q [-\nabla\Phi - \partial_t \mathbf{A}' + c\gamma^5 \boldsymbol{\sigma} \times (\nabla \times \mathbf{A}')] \psi_A$$

Magnetic Flux Quantization

$$q\mathbf{A} = -\hbar \nabla \delta_A / 2$$
$$\mathbf{B} = \nabla \times \mathbf{A}$$

Assume δ_A is a phase shift unique within some multiple of 2π .

The magnetic flux is then quantized:

$$\iint \mathbf{B} \cdot \hat{n} dS = \oint \mathbf{A} \cdot d\mathbf{l} = n\pi \frac{\hbar}{q}$$

Electron Charge

$$q\mathbf{A} = -\hbar \nabla \delta_A / 2$$

$$q\mathbf{E} = \hbar \partial_t \nabla \delta_A / 2 = -\partial_t \mathbf{A}$$

Using $\hbar\omega_e = m_e c^2$, assume:

$$\delta_A = e^2 \frac{(m_\phi \phi - \omega_e t)}{2\pi\epsilon_0 \hbar \omega_e r}$$

Then for $m_\phi = 1/2$:

$$\mathbf{E} = -\frac{e}{4\pi\epsilon_0 r^2}$$

$$\oint A_\phi \cdot r d\phi = \frac{e}{4\epsilon_0 \omega_e r} = \frac{\mu_0 \hbar e}{4m_e r}$$

Correct electron charge and magnetic flux.

Quantum Electrodynamics

Dirac Lagrangian density for two electrons:

$$\mathcal{L} = \psi_A^\dagger [\gamma^\mu (i\partial_\mu - qA_\mu) - m_e] \psi_A \\ + \psi_B^\dagger [\gamma^\mu i\partial_\mu - m_e] \psi_B - \psi_B^\dagger \gamma^\mu \psi_B qA_\mu$$

Each term is zero. Replace second e^- with fields:

$$\mathcal{L} = \psi_A^\dagger [\gamma^\mu (i\partial_\mu - qA_\mu) - m_e] \psi_A + \frac{1}{2} J^\mu A_\mu - \frac{1}{2} J^\mu A_\mu$$

Use Green's first identity:

$$-\int (\nabla^2 \Phi) \Phi dV = \int (\nabla \Phi)^2 dV + \mathbf{b. t.}$$

Also:

$$-\int (\nabla \times \nabla \times \mathbf{A}) \cdot \mathbf{A} dV = -\int (\nabla \times \mathbf{A})^2 dV + \mathbf{b. t.}$$

Quantum Electrodynamics

Result is:

$$\mathcal{L} = \psi_A^\dagger [\gamma^\mu (i\partial_\mu - qA_\mu) - m_e] \psi_A + \frac{1}{2} (E^2 - B^2) - \frac{1}{2} J^\mu A_\mu$$

By convention, the variation of A_μ holds J^μ fixed.

This requires removing the factor of $\frac{1}{2}$:

$$\mathcal{L} = \psi_A^\dagger [\gamma^\mu (i\partial_\mu - qA_\mu) - m_e] \psi_A + \frac{1}{2} (E^2 - B^2) - J^\mu A_\mu$$

This is the non-quantized Lagrangian density of quantum electrodynamics (QED).

Summary of Part III

1. Wave interference yields Pauli exclusion principle and interaction potentials.
2. Magnetic flux quantization results from vector potential \mathbf{A} being proportional to the gradient of a phase angle.
3. Proposed relationship between electric field and magnetic flux is consistent with electron properties.
4. Lagrangian density similar to QED.

Overall Summary

1. Classical wave mechanics is a good tool for modeling the wave behavior of matter.
2. Decomposition of elastic shear waves into interacting “particles” yields dynamics similar to relativistic quantum mechanics.

Publications

- Torsion Waves in Three Dimensions: Quantum Mechanics With a Twist," **Found. Phys. Lett.** 15(1):71-83, Feb. 2002.
- "A Classical Dirac Bispinor Equation," in *Ether Space-time & Cosmology, vol. 3*, eds. M. C. Duffy & J. Levy, (Aperion, Montreal, 2009).
- "Exact Description of Rotational Waves in an Elastic Solid," **Adv. App. Clifford Algebras** 21:273-281, 2010.
- "The Mirror Symmetry of Matter and Antimatter," **Adv. App. Clifford Algebras** 21:283-295, 2010.
- *The Wave Basis of Special Relativity* (Verum Versa, 2014)
- "Spin Angular Momentum and the Dirac Equation," **Electr. J. Theor. Phys.** 12(33):43-60, 2015
- More at: www.ClassicalMatter.org